

## MGBGTV8 – headlamp mounting components - working from the wing outwards

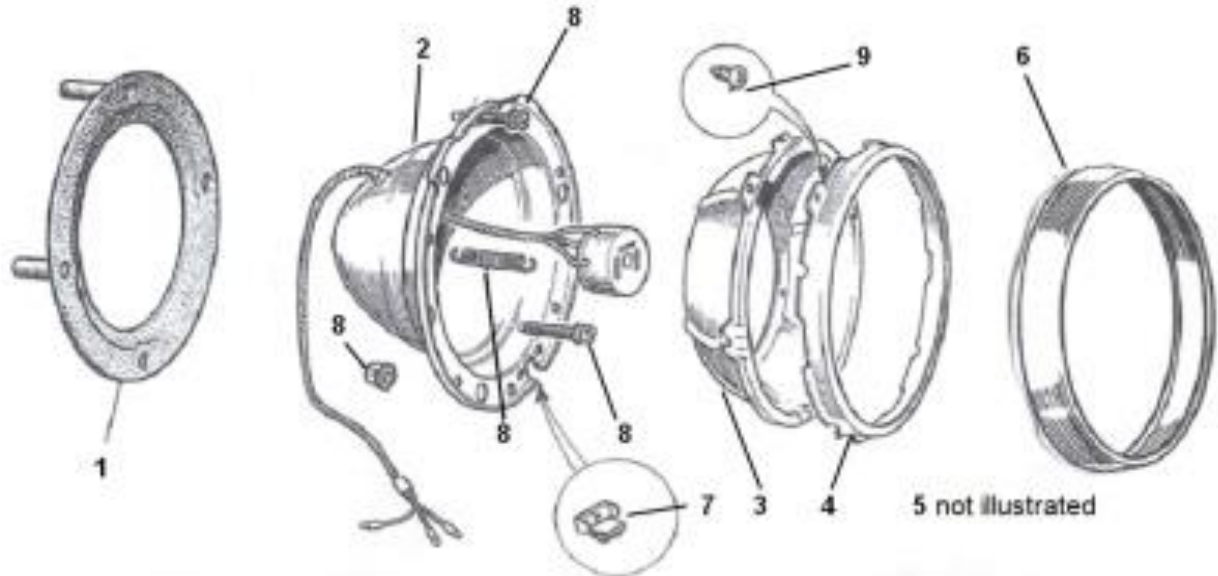

**1**  
**Narrow Inner 28mm wide "Rubber" seating gasket** with two "Ears"  
 MG Rover (Moss Europe) P/N **13H565** & Lucas Holden P/N **54521488**

**2**  
**Steel Headlamp Bucket** (not made by Lucas UK), Moss Europe P/N **SML3** (with adjusters), Moss Europe P/N **SML3Z** (without adjusters) & Lucas Holden P/N **54522342**

**2a**  
**Wipac Plastic Buckets**, benefits they don't rust but they were not designed to fit MGBs. With perseverance they can be a cheap alternative. Make sure the Headlamp Chrome rim finisher fits correctly as you cannot easily fit the **BAU1460** clip to these plastic buckets. Moss Europe P/N **SML3P**, Holden P/N **010.599** & Wipac P/N **S5400**.

**3**  
**Inner retainer headlamp steel bowl zinc plated**, Moss Europe P/N **SML4**, Lucas P/N **54521538**. Plastic alternative, MG Rover (Moss Europe) P/N **27H6481**, Moss Europe P/N **27H6481K** (includes 515218A) & Lucas Holden P/N **54058414** (includes 54521913)

**4**  
**Outer retainer headlamp ring chrome plated**, MG Rover (Moss Europe) P/N **515218A**, Lucas Holden P/N **54521913**, & Wipac P/N **S5401**

**4a**  
**Polished stainless steel version of 4** (instead of chrome plated steel), Holden P/N **010.376**. Also a

Wipac product made for Land Rover Defender 90 aftermarket sold in pairs as P/N **STC3108SS** on EBay. Items 1 to 4 are also available as a set: Moss P/N **27H8263X**. [See link](#)  
 Currently, there seems to be bargain offers on Ebay for a pair (including rims) from H Bowers and others, but I think they are the 3 adjuster BPF bowls with slightly different outer rims May be OK for MGA?  
[See link](#) & [Link](#)

**5**  
**Rubber Ring-Dust Shield**  
 Not originally fitted to V8s but may add some sort of protection against dirt ingress. MG Rover (Moss Europe) P/N **3H2962** & Lucas Holden P/N **552906**.

**6**  
**Headlamp Chrome Rim originally Chrome on Brass.**  
 Measurements from Angloparts website  
 Exterior Dia: 206mm  
 Interior Dia: 183mm  
 Depth: 25mm

**Buyer beware:** There are some Cheap & Nasty Chrome plated Steel rims out there. They Rust. MG Rover (Moss Europe) P/N **57H5296**, Lucas Holden P/N **54521224** & Wipac **S9622**. One has to smile: [See link](#)

**6a**  
**Headlamp rims with 2 notches**  
 In the last years of MGB production Lucas also supplied headlamp rims with two notches in them. (Mainly for the US market). This allowed you to adjust the light beam position without wrestling with the removal of the Chrome headlamp Bezel first. Not cheap but a great

time saver. MG Rover (Moss Europe) P/N **ALU1020** & Lucas P/N **54513938**

**7**  
**CLIP -headlamp rim retaining** (often breaks when removing item 6). MG Rover (Moss Europe) P/N **BAU1460** & Lucas Holden P/N **54522243**.

**8**  
**5 piece inner rim retainer-adjuster kit** contains 1 inner retaining spring plus 2 adjuster screws & plastic nut inserts. MG Rover (Moss Europe) P/N **BHM7058** & Lucas Holden P/N **60600427**.

**9**  
**Last but not least, the three Spring Nut Screws-recessed pan head.** No 6 x 1/4" long under head, zinc plated, they hold item 4 to item 3. Most suppliers today use a pointed self-tapper type AB. Original BMC P/N was **PJZ602**, MG Rover (Moss Europe) supersede this part number to **AB606021**. Original Lucas P/N was **186136**. These days an A2 or A4 stainless steel self tapper is the way to go, try Amazon 3.7p each **MOQ 50** free postage. [Link](#) One can always remove the point by finishing, but don't burn your fingers!

**Buyer beware.** It seems these days one can put anything in a LUCAS Green Box and pass it off as Genuine Lucas. Most of the other MG Specialists will recognise the above numbers I have used in this document. I Have not listed the headlamp wiring (Pigtails), headlamps units & H/L bulbs as there are so many now available.